

Fiber Testers

OPTICAL MULTIMETER

Quick Start Guide **V1.0**

Introduction

The handheld optical multimeter is the integration of power meter, optical light source or visual fault locator, used to measure the optical power loss of the fiber link. It is widely used in the fiber-optic line project construction, testing and maintenance, such as digital data network, telecommunication network and cable television. The figures below display the product images of the two optical multimeters.



FHOM-201



FHOM-103

Accessories

FHOM-201



SC Adapter x1



ST Adapter x1



FC Adapter x1

FHOM-103



SC Adapter x1



ST Adapter x1



FC Adapter x1



USB Cable x1



AC Adapter x1

Installing

Inserting FC Cables

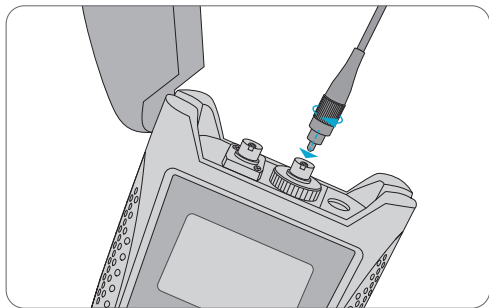

Install FC fiber cable.

Inserting ST Cables

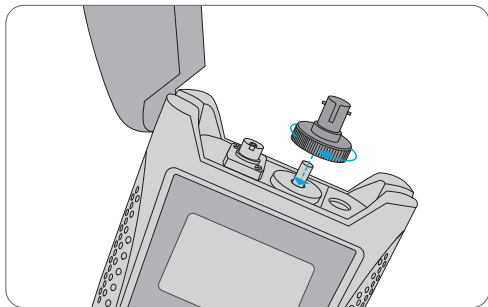

1. Install ST connector.

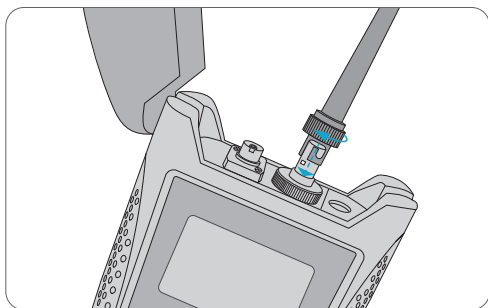

2. Install ST fiber cable.

Inserting SC Cables

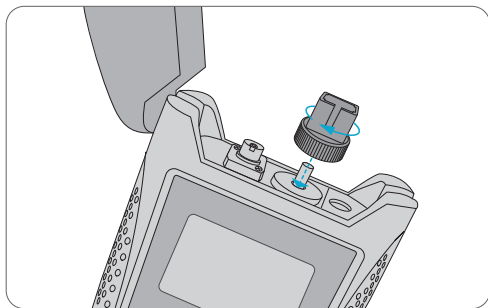

1. Install SC connector.

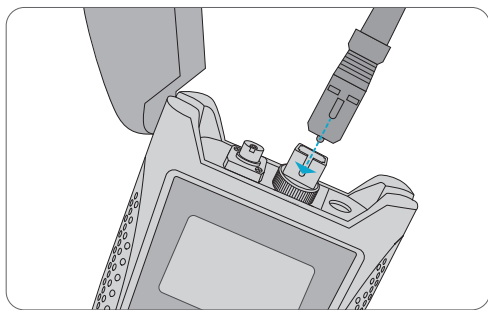









2. Install SC fiber cable.

FHOM-201



Function Introductions



Button	Description
	Power/Backlight Button
	Menu Setting Button
	Up Button
	Save/Query Button
	REF Setting Button
	OPM Wavelength Button
	Laser On/Off Button
	Modulation Button
	OLS Wavelength/Down Button

Operation Instructions



1. Power On/Off and Auto-off Function

Press  button to turn on the instrument, then press for 2 seconds or longer to turn off. This multimeter has a power-saving function. If 10 minutes without any operation, the instrument will automatically shut down. If you need to shield this function and enable the multimeter keep on working, only need to press  button and hold on when you boot the meter. After 2 seconds, the instrument will display  which means permanent power on.

2. Backlight Function

When the instrument is powered on, short press  button to turn on/off backlight. The backlight function support you to use the multimeter at night or darker occasions, and you can set level 0-9. If seting as 0, backlight off, and no backlight even press button.

3. Menu Setting

Press  button to switch each setting interface, then press  or  button to modify the specification. If all finished, press for 2 seconds to exit Menu setting.

4. OPM - Select Wavelength

According to the project's demand, we need to measure optical signals of different wavelengths. Then we need to select a corresponding wavelength to measure the optical power. If the measured wavelength is different from the wavelength we selected on OPM, it will lead to the measuring values meaningless.



After turning on, press  button to switch OPM wavelength from 850nm, 1300nm, 1310nm, 1490nm, 1550nm, 1625nm.

5. OPM - Data Storage/Query

On the OPM interface, long press  button, the display will show "SAVE" and storage number at the top left of the screen and will flash together 3 times. At the same time, the display will show the current stored power value on the screen. After 2 seconds, the multimeter will restore the measuring interface, and save the current measurements in the instrument.

The multimeter can store 1000 records. Each storage number automatically increases one by one, if over the limit, the first data will be overwritten and so on.

On the measuring interface, short press  button to data-saving interface, you can

check the newest stored data. Then short press  button and  button to check the previous stored data. Short press  button to exit the data-saving interface.

6. OPM - Reference

 button is used to set the reference value or switch the absolute or relative value. Press for 2 seconds or longer, "REF" sign will display on the screen after flashing 3 times, the instrument will use the current measurements to overwrite the original setting value and set it as a new reference value. Meanwhile LCD will display set REF value (dBm) and dB value. Each wavelength can set their own reference value.

Short press  button can convert between absolute and relative value. The absolute value on the screen will display the measuring absolute value (dBm/uW), the relative value on the screen will display the "REF", the setting REF value (dBm) and the difference between actual measured value and reference value (dB).

7. OLS - Laser On/Off

When the instrument is powered on, short press  button to turn on/off OLS function. If OLS is off, it will display "OFF" in the LCD. If OLS is on, it will display the current wavelength of OLS.

8. OLS - Select Wavelength

When turning on OLS, press  button to select the output wavelength you need. If using other OPM to test the OLS power, then the OPM should select the same wavelength as OLS has.









9. OLS - Modulation Output

Short press  button, you can load a modulation in the current output laser, and display modulation (270Hz, 1kHz, 2kHz). Connecting with an optical power meter with frequency identification function, the OPM can identify the laser's current load modulation, and load a same frequency.

FHOM-103

Function Introductions



Button	Description
	Power/Backlight Button
	OPM Wavelength Shift/WAVE ID Button
	VFL On/Off Button
	OPM Data Save/Recall Button
	OPM Unit Shift Button
	OPM Reference Check/Set Button
	Laser Source On/Off Button
	Laser Source Wavelength Shift Button
	Laser Source Modulation Button

Operation Instructions

1. Power On/Off and Auto-off Function

Press  button to turn on the instrument with auto power off. If 10 minutes with any operation, it will automatically shut down.

Press  button for 2 seconds when turn on the instrument, the auto-off function will be canceled, and the LCD will show "PERM". Also press it for 2 seconds to turn off the instrument.

2. Backlight

When the instrument power on, press  button to turn on or turn off the backlight.

3. OPM - Select Wavelength



When testing, you must select the right wavelength. Press  button for shifting the wavelength from: 850nm, 1300nm, 1310nm, 1490nm, 1550nm, 1625nm.

4. OPM - WAVE ID (optional)

Long press  button to turn on the WAVE ID and display "id" at the same time.

Long press again to exit the WAVE ID.

5. OPM - Select Unit

Press  button for shifting the unit from: dBm, nW/uW/mW, after pressing  button, it shifts to dB. After power off, the current unit will be saved.

nW/uW/mW: 1mW = 1000uW, 1uW = 1000nW

dBm: $(dBm) = 10 * \log(mW)$

dB: $(dB) = dBm - REF$

6. OPM - Reference

Press  button to check the reference value you set last time. And if keep pressing for 2 seconds, you can store the current dBm as a new reference value. Then it automatically shifts to dB.

$dB = dBm - REF$

You can store the REF value for each wavelength.

7. OPM - Data Storage

Short press  button to check the data storage.

Press  button and  button to change previous/next record.

Long press  button to save the current value.

8. OLS On/Off

Press  button to turn on/off the laser source output.

9. OLS - Select Wavelength/WAVE ID

Short press  button to shift the wavelength. Long press (>2s) the button to turn on WAVE ID function, the wavelength glints on LCD. Long press it again to turn off the function.

10. OLS - Modulation Select

Press  button to shift from 270Hz, 1KHz, 2KHz.

11. Visual Fault Locator (optional)

The instrument can be built in an optional VFL module. Press  button to shift the conditions: on-> glint-> off.

12. Battery Energy Detect

 Sufficient power

 More power

 Less power

 Insufficient battery power

13. Battery Charge

When you use rechargeable batteries and the meter indicates insufficient power, it should be turned off and charged. Long time under voltage will cause the life of the battery to be shortened.

When charging, the battery indication on LCD will flash. After charging fully, the indication will stop flashing and show full. Don't charge for more than 48 hours.

If charging while using the device, the time will be longer.

Rechargeable batteries must be in device when you use the AC/DC adaptor for charging. And do not charge the non-rechargeable batteries, or the device will be destroyed and also lose the guarantee.

Maintenance

- (1) The interface is sensitive, please carefully plug in and pull out connectors.
- (2) Keep using one type of optical adapter to avoid excess loss from different connectors.
- (3) Please use dust-proof cap for protection to avoid being scratched or contaminated when not in operation.
- (4) It is important to keep all optical connectors and surfaces free from oil, dirt, or other contamination to ensure proper operation.
- (5) In order to avoid the electric shock, please do not disassemble the components. Disobeying the standard instruction may lead to safety issues.
- (6) Remove the batteries when the battery power becomes weak or when the instrument is not in use for extended periods. This will prevent damage to the multimeter from battery leakage at such time.

Online Resources

- Download <https://www.fs.com/download.html>
- Help Center https://www.fs.com/service/help_center.html
- Contact Us https://www.fs.com/contact_us.html

Product Warranty

FS ensures our customers that any damage or faulty items due to our workmanship, we will offer a free return within 30 Days from the day you receive your goods.



Warranty: All Optical Multimeters enjoy 1 year limited warranty against defect in materials or workmanship. For more details about warranty, please check at <https://www.fs.com/policies/warranty.html>



Return: If you want to return item(s), information on how to return can be found at https://www.fs.com/policies/day_return_policy.html

Q.C. PASSED